



VBV-770FM vehicle CCTV monitor

Quick installation guide

Guide d'installation rapide

Kurzanleitung

Guida d'installazione rapida

Guía rápida de instalación

Snelle installatie handleiding

Guia rápida de instalação

Руководство по быстрой установке

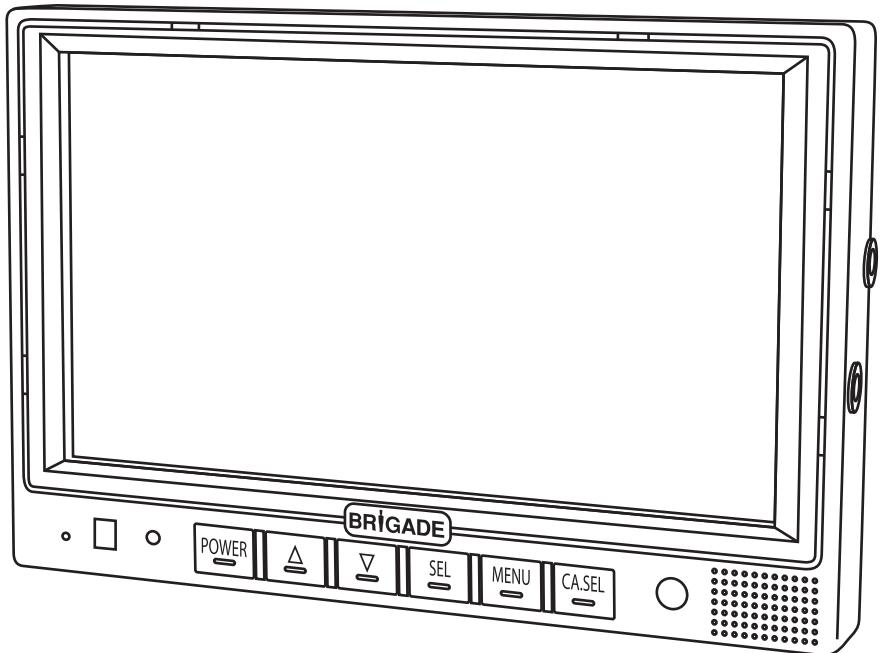

Stock code #3904A



1 Contents

Contenu/Inhalt/Contenuto/Contenido/inhoud/Conteúdo/Содержание

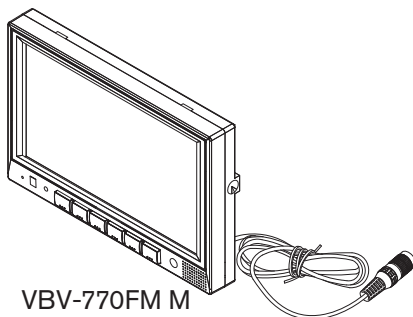

VBV-770FM M

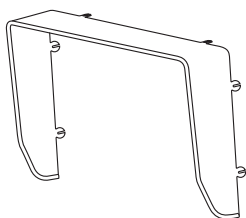

VBV-770DM SS

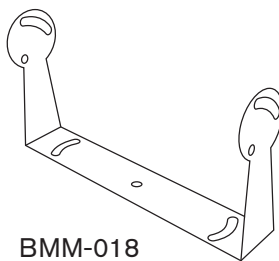

BMM-018

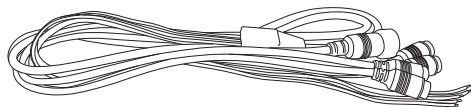

VBV-7104FM-CA

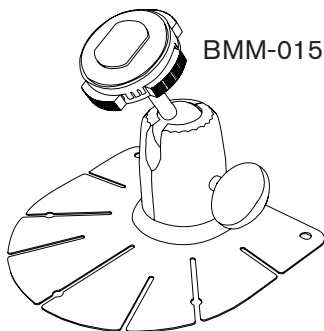

BMM-015

2 Monitor installation

Surveiller l'installation/Monitor-Einbau/Installazione del monitor/
Instalación del monitor/Monitor installatie/ Instalação do monitor/
Расположение камеры

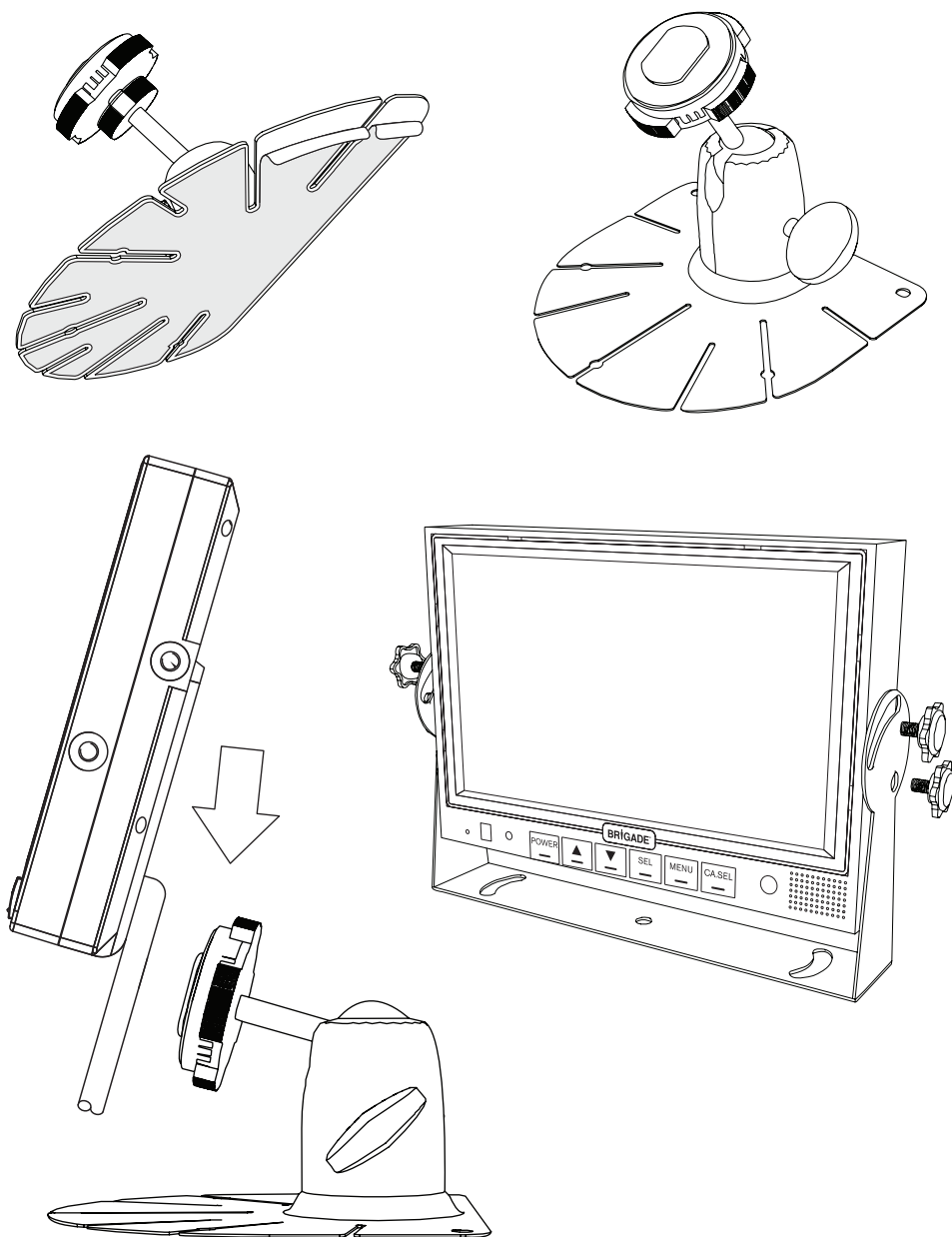

4 Controls

Contrôles/Bedienung/Controlli/Controles/Controles/Controles/контроля

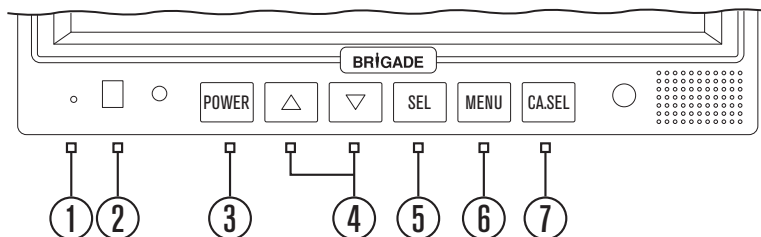

- ① Automatic low light sensor.
Capteur optique automatique de basse luminosité.
Licht Sensor.
Sensore automatico di bassa luminosità.
Sensor automático de baja luminosidad.
Automatische lage lichtsensor.
Sensor de luz baixa automática.
Автоматический датчик низкой освещенности.
- ② Remote control receiver.
Récepteur de la télécommande.
Empfänger für Fernbedienung.
Ricevitore per telecomando.
Receptor de control remoto.
Afstandsbediening ontvanger.
Receptor de controle remoto.
Приемник дистанционного управления.

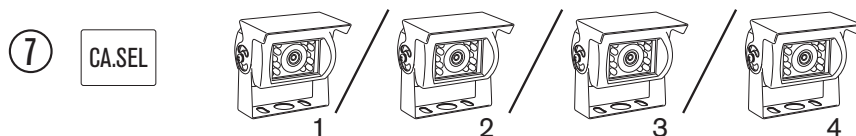
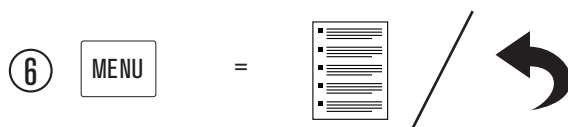

5 Operation

Opération/Betrieb/Operazione/Operación/Werking/Operação

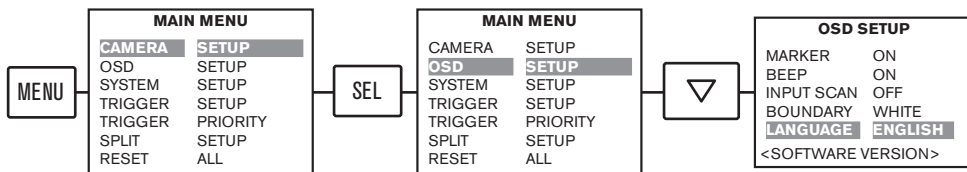

Button lock

Bouton de verrouillage/Tastensperre/Blocco dei pulsanti/
Bloqueo de botones/Knopvergrendeling/Bloqueio dos botões

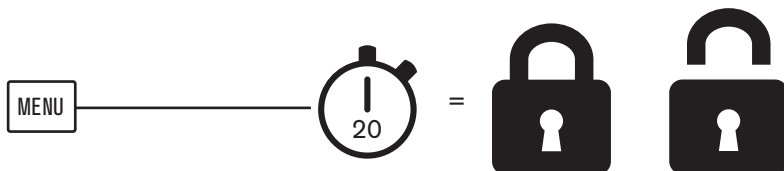

MARKER SETTING

Mise en marqueur/Einstellung der Markierungen/Impostazione dei marcatori/
Ajuste de los marcadores/Marker instelling/Definir os marcadores

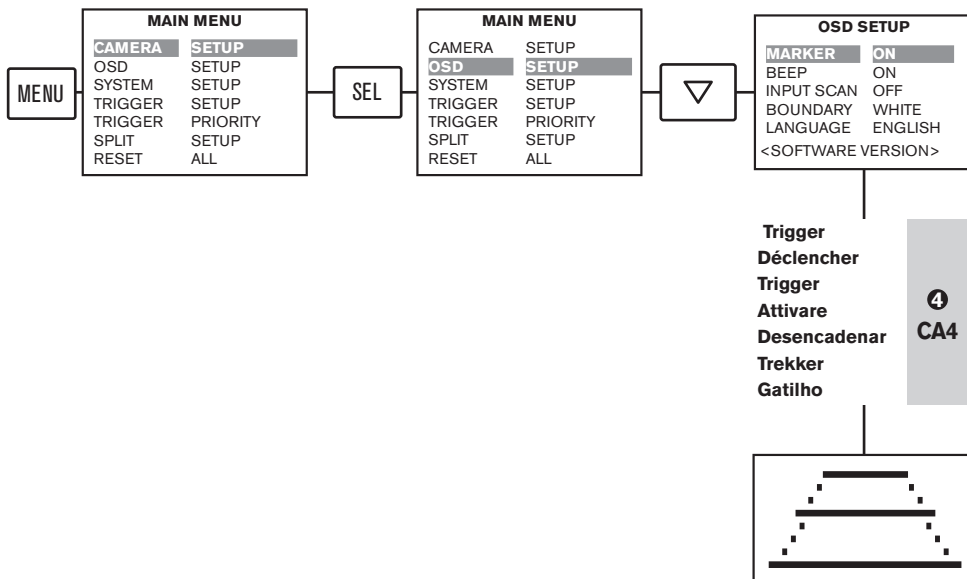

5 Operation

Opération/Betrieb/Operazione/Operación/Werking/Operação

Split setting

Mise en diviser/Split-Einstellung/Impostazione Divisione/Ajuste de la Division/
Split instelling/Definir Divisão

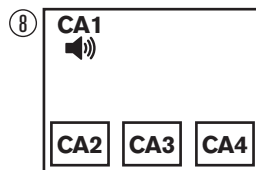
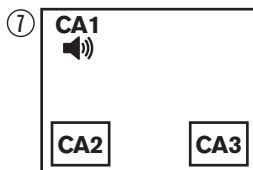
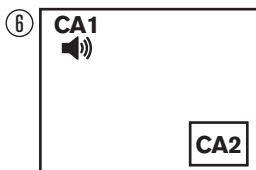
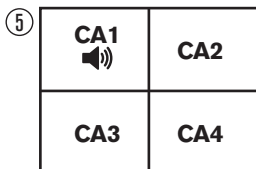
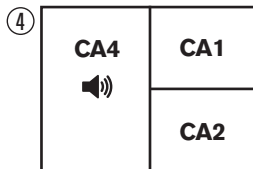
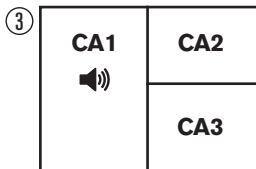
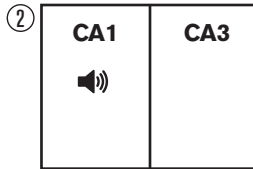
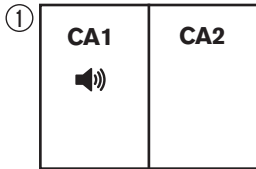
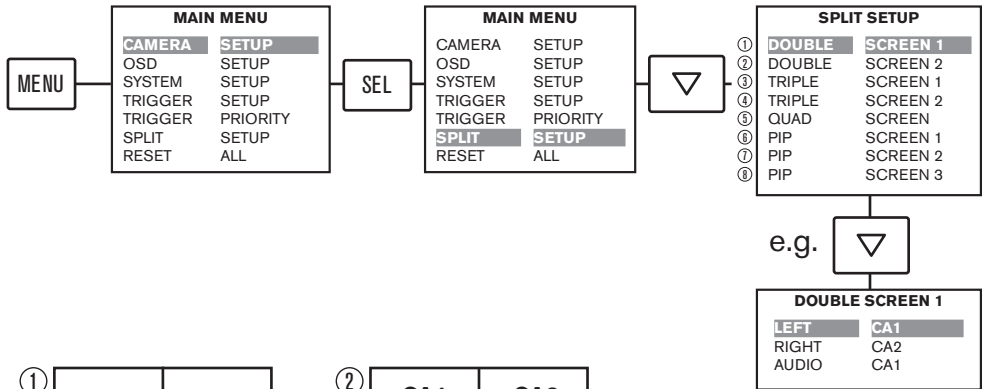

5 Operation

Opération/Betrieb/Operazione/Operación/Werking/Operação

Trigger setting

Paramètre de déclenchement/Trigger-Einstellung/Impostazione trigger/
Configuración de disparadores/Drempelwaarde/Configuração de acionadores

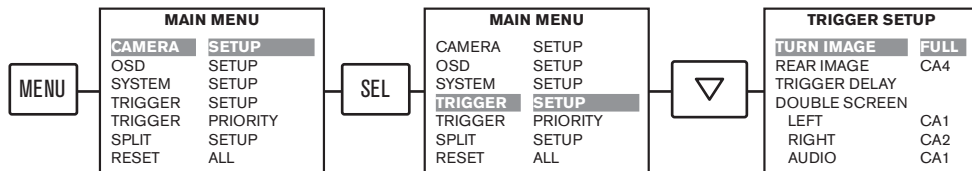

Trigger delay

Retard déclenche/Trigger Verzögerung/Ritardo trigger/Retraso de disparador/
Trigger vertraging/ Tempo de activação

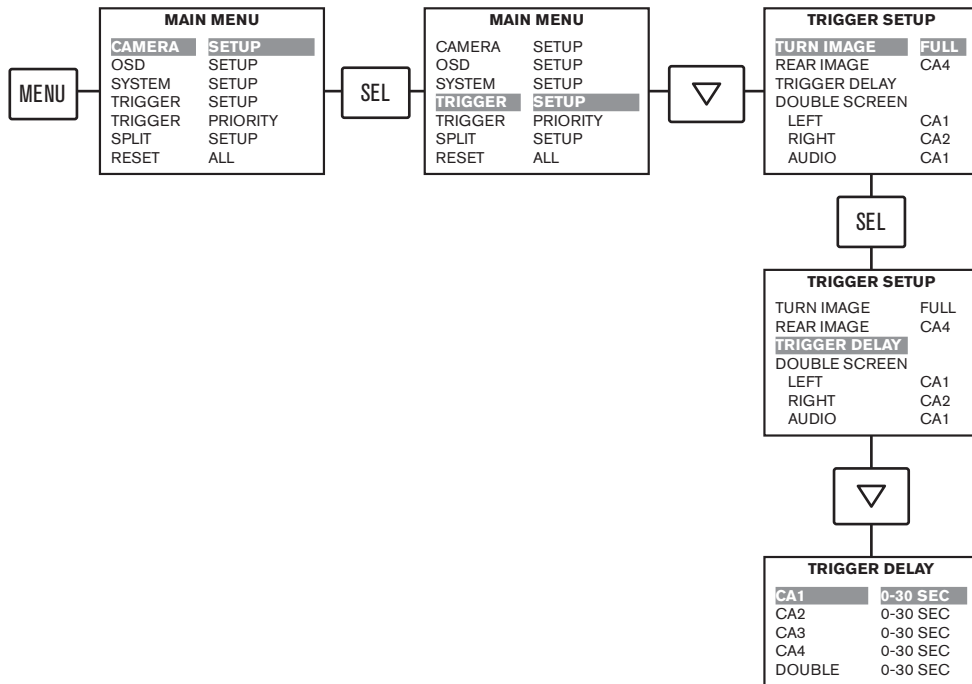

6 Specifications

Spécifications/Spesifikationer/Specifiche/Especificaciones/Specificaties/Especificações/Спецификация

ENGLISH	
Specifications	
Monitor	VBV-770FM
TV system	NTSC/PAL
Picture	7" Digital TFT LCD colour monitor with on-screen display function
Display size	7" diagonal
Field of view	Top: 70°, Bottom: 50°, Left: 70°, Right: 70°
Resolution	(800x(RGB)x480)
Picture image	Factory set to reverse image
Power	12/24Vdc input
Inputs	4 x camera
Dimensions	182(w) x 122(h) x 29.5(d)mm 7.17(w) x 4.8(h) x 1.17(d) inches
Operating temperature	-30°C ~ +70°C -40°F ~ +158°F

FRANCAIS	
Specifications	
Moniteur	VBV-770FM
Système TV	NTSC/PAL
Image	7" Numérique TFT LCD moniteur couleur avec affichage de fonction (OSD)
Dimension de l'écran	7" diagonale
Champ de vision	Haut: 70°, Bas: 70°, Gauche: 70°, Droite: 70°
Résolution	(800x(RGB)x480)
Image vidéo	Réglage d'usine sur image inverse
Alimentation	12/24Vdc input
Entrées	4 x caméra
Dimensions	182(w) x 122(h) x 29,5(d)mm 7,17(w) x 4,8(h) x 1,17(d) inches
Température d'utilisation	-30°C ~ +70°C -40°F ~ +158°F

ITALIANO	
Specifiche	
Schermo	VBV-770FM
Sistema TV	NTSC/PAL
Immagine	7" digital TFT LCD colorare il monitor con la funzione di mostra sullo schermo
Formato display	7" diagonale
Campo visivo	Top: 70°, Bottom: 50°, Left: 70°, Right: 70°
Risoluzione	(800x(RGB)x480)
Immagine a video	Immagine reversibile programmabile
Alimentazione	12/24Vdc input
Prese	4 x telecamera
Dimensioni	182(w) x 122(h) x 29,5(d)mm 7.17(w) x 4.8(h) x 1.17(d) inches
Temperatura di servizio	-30°C ~ +70°C -40°F ~ +158°F

DEUTSCH	
Spezifikationen	
Monitor	VBV-770FM
TV-System	NTSC/PAL
Bild	7" digitalen TFT LCD Farbmonitor mit Funktionsanzeige (OSD)
Bildschirmgröße	7" diagonal
Sichtfeld	Oben: 70°, Unten: 50°, Links: 70°, Rechts: 70°
Auflösung	(800x(RGB)x480)
Videobild	Werkseinstellung Reversebild
Stromversorgung	12/24Vdc input
Eingänge	4 x Kamera
Abmessungen	182(w) x 122(h) x 29,5(d)mm 7.17(w) x 4.8(h) x 1.17(d) inches
Betriebstemperatur	-30°C ~ +70°C -40°F ~ +158°F

6 Specifications

Spécifications/Spesifikationen/Specifiche/Especificaciones/Specificaties/Especificações/Спецификация

ESPAÑOL	
Especificaciones	
Monitor	VBV-770FM
Sistema de TV	NTSC/PAL
Imagen	Monitor a color de 7" digital TFT LCD con visualización de las funciones (OSD)
Tamaño de pantalla	7" diagonal
Campo visual	arriba: 70°, abajo: 50°, a la izquierda: 70°, a la derecha: 70°
Resolución	(800x(RGB)x480)
Imagen de video	Ajuste de fábrica de la imagen inversa
Suministro de corriente	12/24Vdc entrada
Entradas	4 x cámara
Dimensiones	182(w) x 122(h) x 29.5(d)mm 7.17(w) x 4.8(h) x 1.17(d) inches
Temperatura de servicio	-30°C ~ +70°C -40°F ~ +158°F

NEDERLANDS	
Specificaties	
Monitor	VBV-770FM
TV-systeem	NTSC/PAL
Beeld	7" digitale TFT LCD kleurenmonitor met on-screen display functie
Displayformaat	7" diagonaal
Gezichtsveld	Boven: 70°, Onder: 50°, Links: 70°, Rechts: 70°
Resolutie	(800x(RGB)x480)
Videobeeld	Fabrieksinstelling reversebeeld
Stroomvoorziening	12/24Vdc Ingang
Ingangen	4 x camera
Afmetingen	182(w) x 122(h) x 29.5(d)mm 7.17(w) x 4.8(h) x 1.17(d) inches
Bedrijfstemperatuur	-30°C ~ +70°C -40°F ~ +158°F

PORTUGUÊS	
Especificaciones	
Monitor	VBV-770FM
Sistema de TV	NTSC/PAL
Imagen	Monitor a color de 7" TFT LCD con visualización de las funciones (OSD)
Tamaño de pantalla	7" diagonal
Campo visual	arriba: 70°, abajo: 50°, a la izquierda: 70°, a la derecha: 70°
Resolución	(800x3(RGB)x480)
Imagen de video	Ajuste de fábrica de la imagen inversa
Suministro de corriente	12/24Vdc entrada
Entradas	4 x cámara
Dimensiones	182(w) x 122(h) x 29.5(d)mm 7.17(w) x 4.8(h) x 1.17(d) inches
Temperatura de servicio	-30°C ~ +70°C -40°F ~ +158°F

Русский	
Спецификация	
монитор	VBV-770FM
ТВ-система	NTSC/PAL
изображение	7 "TFT LCD цветной монитор с функцией индикации на экране
размер дисплея	7" диагональ
Угол обзора	топ: 70°, дно: 50°, слева: 70°, право: 70°
Разрешение	(800x3(RGB)x480)
фото изображение	заводская настройка обратного изображения
Напряжение	12/24Vdc затраты
затраты	4 x камеры
размеры	182(ш) x 122(в) x 29.5(г)mm 7.17(ш) x 4.8(в) x 1.17(г) дюймов
Рабочая температура	-30°C ~ +70°C -40°F ~ +158°F

Disclaimer

Camera monitor systems are an invaluable driver aid but do not exempt the driver from taking every normal precaution when conducting a manoeuvre. No liability arising out of the use or failure of the product can in any way be attached to Brigade or to the distributor.

Dénégation

Les systèmes de moniteurs des caméras sont une aide précieuse pour le conducteur, mais celui-ci doit toutefois prendre toutes les précautions nécessaires pendant les manœuvres. Brigade ou ses distributeurs n'assument aucune responsabilité résultant de l'utilisation ou d'un défaut du produit.

Haftungsausschluss

Kamera-Monitor-Systeme sind für den Fahrer eine unschätzbare Hilfe, ersetzen aber beim Manövrieren keinesfalls die üblichen Vorsichtsmaßnahmen. Für Schäden aufgrund der Verwendung oder eines Defekts dieses Produkts übernehmen Brigade oder der Vertriebshändler keinerlei Haftung.

Condizioni di Utilizzo

I sistemi di telecamere e monitor costituiscono un prezioso ausilio alla guida, ma il conducente deve comunque assicurarsi di prendere tutte le normali precauzioni quando esegue una manovra. Né Brigade né il suo distributore saranno responsabili per eventuali danni di qualsiasi natura causati dall'utilizzo o dal mancato utilizzo del prodotto.

Aviso legal

Aunque los sistemas de cámaras con pantalla constituyen una valiosa ayuda, no eximen al conductor de tomar todas las precauciones normales al hacer una maniobra. Brigade y sus distribuidores comerciales no se responsabilizan de cualquier daño derivado del uso o de un mal funcionamiento del producto.

Declinação de responsabilidade

Os sistemas de monitoria da câmara são uma ajuda incalculável ao motorista, mas não dispensam o motorista de tomar todas as precauções normais ao realizar uma manobra. Nenhuma responsabilidade decorrente do uso ou falha do produto pode de forma alguma ser atribuída ao Brigade ou ao distribuidor.

Verwerping

De camera-monitorsystemen zijn een waardevolle hulp voor de bestuurder, maar ontheffen hem echter niet van de verplichting om het voertuig zorgvuldig te manoeuvreren. Brigade en zijn distributeurs zijn niet aansprakelijk voor schade door gebruik of het niet functioneren van het product.

Отказ от обязательств

Системы камерного слежения являются крайне полезным средством помощи водителю, но не освобождают водителя от обязанности соблюдения всех необходимых мер предосторожности при совершении маневра. На компанию Brigade или распространителя продукции не налагается никакая ответственность, возникающая по причине использования или неисправности данного продукта.

Specifications subject to change. Sous réserve de modifications techniques. Änderungen an den technischen Daten vorbehalten. Specifiche soggette a variazioni. Las especificaciones están sujetas a cambios. Wijzigingen in specificaties voorbehouden. As especificações estão sujeitas a alterações. Спецификация может изменяться.

Serial No:

Part No:



www.brigade-electronics.com

